

Save This Manual for Future Reference

Original Instruction



Mini transporter

Operator's Manual

MODEL NUMBER : 0301A

SERIAL NUMBER : _____

Both model number and serial number may be found on the CE label.

You should record both of them in a safe place for future use.

FOR YOUR SAFETY

READ AND UNDERSTAND THE ENTIRE MANUAL BEFORE
OPERATING MACHINE

TABLE OF CONTENTS

Introduction	1
Specifications	1
Symbols	1
Safety	2
General Safety Rules	2
Specific Safety Rules	3
Contents Supplied	4
Assembly	5
Know your mini transporter	6
Features&Controls	6
Mini transporter operation	7
Maintenance	8
Storage	9
Trouble shooting	10
Parts schedule	11

INTRODUCTION

Your new mini transporter will more than satisfy your expectations. It has been manufactured under stringent quality standards to meet superior performance criteria. You will find it's easy and safe to operate, and with proper care, it will give you many years of dependable service.



Carefully read through this entire operator's manual before using this unit. Take special care to heed the cautions and warnings.

The four-speed gearbox, three forward and one reverse, lies at the heart of the unit. It is oversized so as to manage safely the huge torques generated by the engine. Thanks to its efficient reduction gearing, it is capable of moving around in every situation and bearing any load.

The Engine manufacturer is responsible for all engine-related issues with regards to performance, power rating, specifications, warranty and service. Please refer to the engine manufacturer's owner's/operator's manual, packed separately with your unit for more information.

Specifications

Item No.	0310A
Engine	196cc.6.5HP
Transmission	3R+1R
Load capacity	300kg
Box Length	900mm
Box Width	670mm
Box Depth	290mm
Track Width	180mm
Sound power lever(LWA)	103dB(A)
Weight	178kg

ENVIRONMENTAL



Recycle unwanted materials instead of disposing of them as waste. All tools, hoses and packaging should be resorted, taken to the local recycling center and disposed of in an environment-friendly safe way.

SYMBOLS

There are relevant symbols stuck on your machine which represent important information about the product or instructions on its use.



Wear eye protection. Wear hearing protection.



Read these instructions for use carefully.



Wear safety footwear.



Wear safety gloves.



It is forbidden to remove or tamper with the protection devices and safety devices.



Keep away from hot parts on the machine.



Do not smoke or have open flames.



Thrown objects.



Keep your hands or feet away from track and rotating parts.



Keep bystanders away.

SAFETY

General Safety Rules

Understand your machine

Read and understand the operator's manual and labels affixed to the machine. Learn its application and limitations as well as the specific potential hazards peculiar to it.

Be thoroughly familiar with the controls and their proper operation. Know how to stop the machine and disengage the controls quickly.

Make sure to read and understand all the instructions and safety precautions as outlined in the **Engine Manufacturer's Manual**, packed separately with your unit. Do not attempt to operate the machine until you fully understand how to properly operate and maintain the Engine and how to avoid accidental injuries and/or property damage.

Work area

Never start or run the machine inside a closed area. The exhaust fumes are dangerous, containing carbon monoxide, an odorless and deadly gas. Operate this unit only in a well ventilated outdoor area.

Never operate the machine without good visibility or light.

Personal safety

Do not operate the machine while under the influence of drugs, alcohol, or any medication that could affect your ability to use it properly.

Dress properly

Wear heavy long pants, boots and gloves. Do not wear loose clothing, short pants, and jewelry of any

kind. Do not wear Secure long hair so it is above shoulder level. Keep your hair, clothing and gloves away from moving parts. Loose clothes, jewelry or long hair can be caught in moving parts.

Use safety equipment

Always wear eye protection. Safety equipment such as a dust mask, hard hat, or hearing protection used for appropriate conditions will reduce personal injuries.

Check your machine before starting it. Keep guards in place and in working order. Make sure all nuts, bolts, etc. are securely tightened.

Never operate the machine when it is in need of repair or is in poor mechanical condition. Replace damaged, missing or failed parts before using it. Check for fuel leaks. Keep the machine in safe working condition.

Never remove or tamper with safety device. Check their proper operation regularly.

Do not use the machine if the engine's switch does not turn it on or off. Any gasoline powered machine that can not be controlled with the engine switch is dangerous and must be replaced.

Form a habit of checking to see that keys and adjusting wrenches are removed from machine area before starting it. A wrench or a key that is left attached to a rotating part of the machine may result in personal injury.

Stay alert, watch what you are doing and use common sense when operating the machine.

Do not overreach. Do not operate the machine while barefoot or when wearing sandals or similar lightweight footwear. Wear protective footwear that will protect your feet and improve your footing on slippery surfaces. Keep proper footing and balance at all times. This enables better control of the machine in unexpected situations.

Avoid accidental starting. Be sure the engine is off before transporting the machine or performing any maintenance or service on the unit. Transporting or performing maintenance or service on a machine with engine on invites accidents.

Fuel safety

Fuel is highly flammable, and its vapors can explode if ignited. Take precautions when using to reduce the chance of serious personal injury.

When refilling or draining the fuel tank, use an approved fuel storage container while in a clean, well-ventilated outdoor. Do not smoke, or allow sparks, open flames or other sources of ignition near the area while adding fuel or operating the unit. Never fill fuel tank

indoors.

Keep grounded conductive objects, such as tools, away from exposed, live electrical parts and connections to avoid sparking or arcing. These events could ignite fumes or vapors.

Always stop the engine and allow it to cool before filling the fuel tank. Never remove the cap of the fuel tank or add fuel while the engine is running or when the engine is hot. Do not operate the machine with known leaks in the fuel system.

Loosen the fuel tank cap slowly to relieve any pressure in the tank.

Never over fill fuel tank. Fill tank to no more than 12.5mm (1/2") below the bottom of the filler neck to provide space for expansion as the heat of the engine can cause fuel to expand.

Replace all fuel tank and container caps securely and wipe up spilled fuel. Never operate the unit without the fuel cap securely in place.

Avoid creating a source of ignition for spilled fuel. If fuel is spilled, do not attempt to start the engine but move the machine away from the area of spillage and avoid creating any source of ignition until fuel vapors have dissipated.

Store fuel in containers specifically designed and approved for this purpose.

Store fuel in a cool, well-ventilated area, safely away from sparks, open flames or other sources of ignition.

Never store fuel or machine with fuel in the tank inside a building where fumes may reach a spark, open flame, or other sources of ignition, such as a water heater, furnace, clothes dryer and the like. Allow the engine to cool before storing in any enclosure.

Machine use and care

Position the machine in such a way that it can not move during maintenance, cleaning, adjustment, assembly of accessories or spare parts, as well as under storage.

Do not force the machine. Use the correct machine for your application. The correct machine will do the job better and safer at the rate for which it was designed.

Do not change the engine governor settings or over-speed the engine. The governor controls the maximum safe operating speed of the engine.

Do not run the engine at a high speed when you are not working.

Do not put hands or feet near rotating parts.

Avoid contact with hot fuel, oil, exhaust fumes and

hot surfaces. Do not touch the engine or muffler. These parts get extremely hot from operation. They remain hot for a short time after you turn off the unit. Allow the engine to cool before doing maintenance or making adjustments.

If the machine should start to make an unusual noise or vibration, immediately shut off the engine, disconnect the spark plug wire, and check for the cause. Unusual noise or vibration is generally warning of trouble.

Use only attachments and accessories approved by the manufacturer. Failure to do so can result in personal injury.

Maintain the machine. Check for misalignment or binding of moving parts, breakage of parts and any other condition that may affect the machine's operation. If damaged, have the machine repaired before use. Many accidents are caused by poorly maintained equipment.

Keep the engine and muffler free of grass, leaves, excessive grease or carbon build up to reduce the chance of a fire hazard.

Never douse or squirt the unit with water or any other liquid. Keep handles dry, clean and free from debris. Clean after each use.

Observe proper disposal laws and regulations for gas, oil, etc. to protect the environment.

Store idle machine out of the reach of children and do not allow persons unfamiliar with the machine or these instructions to operate it. Machine is dangerous in the hands of untrained users.

Service

Before cleaning, repair, inspecting, or adjusting, shut off the engine and make certain all moving parts have stopped. Disconnect the spark plug wire, and keep the wire away from the plug to prevent accidental starting.

Have your machine serviced by qualified repair personnel using only identical replacement parts. This will ensure that the safety of the machine is maintained.

Specific Safety Rules

Thoroughly inspect the area to be worked, keep the working area clean and free of debris to prevent tripping. Operate on a flat level ground.

Never place any part of your body where it would be in danger if movement should occur during assembly, installation, and operation, maintenance, repairing or moving.

Keep all bystanders, children, and pets at least 23m (75feet) away. If you are approached, stop the unit

immediately.

Do not mount on dump box and never carry passengers.

Never park the machine in a place with unstable ground which could give way, particularly when it is full.

Disengage clutch lever before starting the engine.

Start the engine carefully according to instructions and with feet well away from the moving parts.

Never leave the operating position when the engine is running.

Always hold the unit with both hands when operating. Keep a firm grip on the handlebars. Be aware that the machine may unexpectedly bounce upward or jump forward if the machine should strike buried obstacles such as large stones.

Walk, never run with the machine.

Do not overload the machine capacity.

Drive at a safe speed, adjusting the speed to the slope of the land, the surface conditions of the road, and the weight of the load.

Use extreme caution when in reverse or pulling the machine towards you.

Exercise extreme caution when operating on or

crossing gravel drives, walks, or roads. Stay alert for hidden hazards or traffic.

On soft ground, drive at the first forward/reverse gear.

Do not rapidly accelerate, turn sharply or stop.

Pay the utmost attention when working on frozen ground as the machine may tend to skid.

If possible, avoid driving on pebbly river bed, crushed stone terrains, steel concrete, stumpy field, logs etc., since such operation causes fatal damage or shortens life span of tracks.

Do not operate the machine in confined areas where there may be a risk of crushing the operator between the machine and another object.

Never operate the machine on slopes where angle is over 20°.

When moving over a slope, whether moving forward or in reverse, always make certain that the weight is evenly balanced. Always move in directions parallel with the slope (up or down). To avoid danger, do not shift gears on slopes.

When tipping the load from a dumper, the center of gravity will change continuously and the ground conditions will be essential for the stability of the machine. There are special hazards for dumpers working on soft ground and when the load is sticking to body e.g. wet clay.

CONTENTS SUPPLIED

The mini transporter comes partially assembled and is shipped in carefully packed package. After all the parts have been removed from the package, you should have:

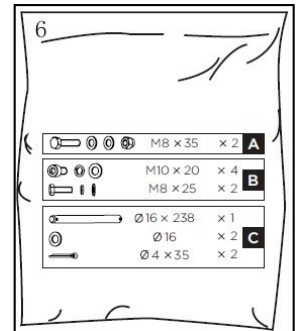
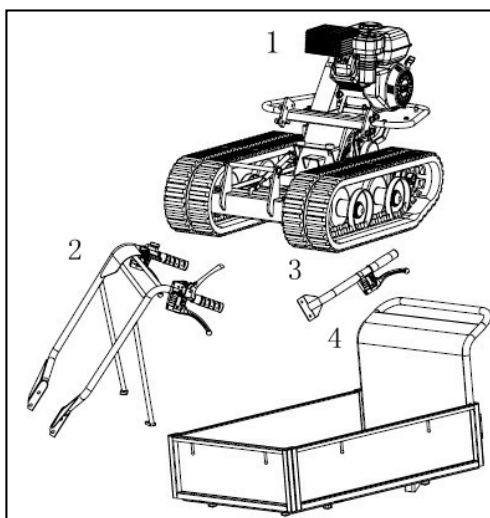

1. Main Frame
2. Handlebar Assembly
3. Tipping Handle
4. Dumper Box
5. Operator's Manual
6. Hardware Bag

ASSEMBLY

Following the assembly instructions below, you will assemble the machine in a few minutes:

1. Mount the tipping handle on panel right side. Align holes and fasten with two M8x30 hex bolts, four washers and two nuts.

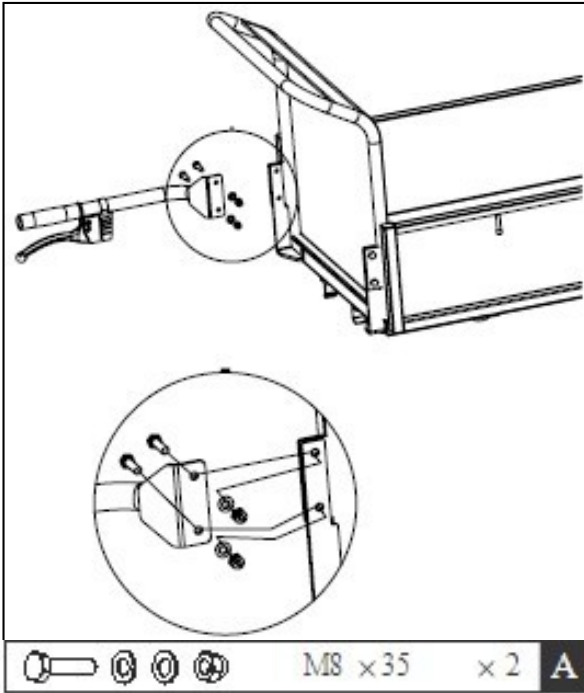

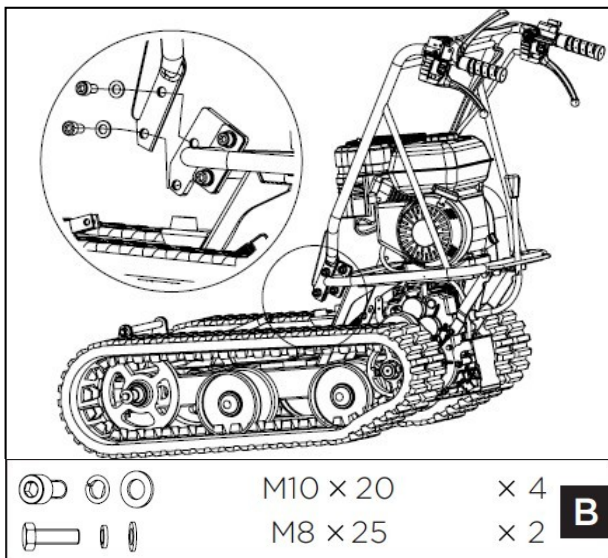

2. Align the holes of the handlebar with the mount bracket and secure each with a spring washer, flat washer and a M10x20 bolt. Fasten each handlebar support onto the engine deck with a spring washer, flat washer and a M8x25 hex bolt.

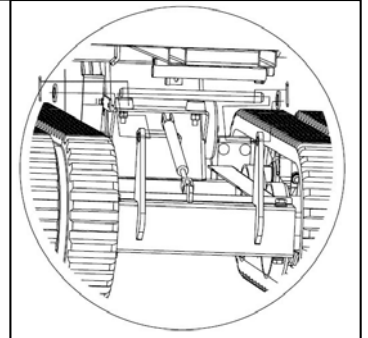
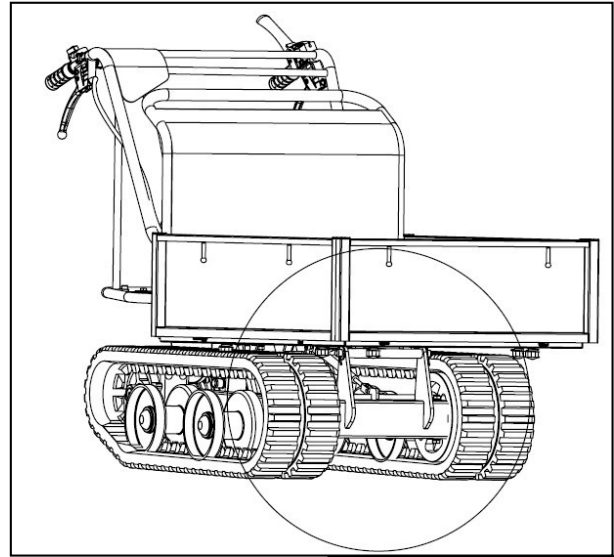

3. Position the bottom panel inside the mounting bracket. Align the holes with the mounting bracket. Insert a long pin through holes and secure each side with a flat washer and cotter pin.

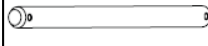

	Ø 16 x 238	x 1	C
	Ø 16	x 2	
	Ø 4 x 35	x 2	

Engine oil



Oil has been drained for shipping. Failure to fill engine sump with oil before starting engine will result in permanent damage and will void engine warranty.

Add oil according to Engine Manual packed separately with your unit.

KNOW YOUR MINI TRANSPORTER

Features and Controls

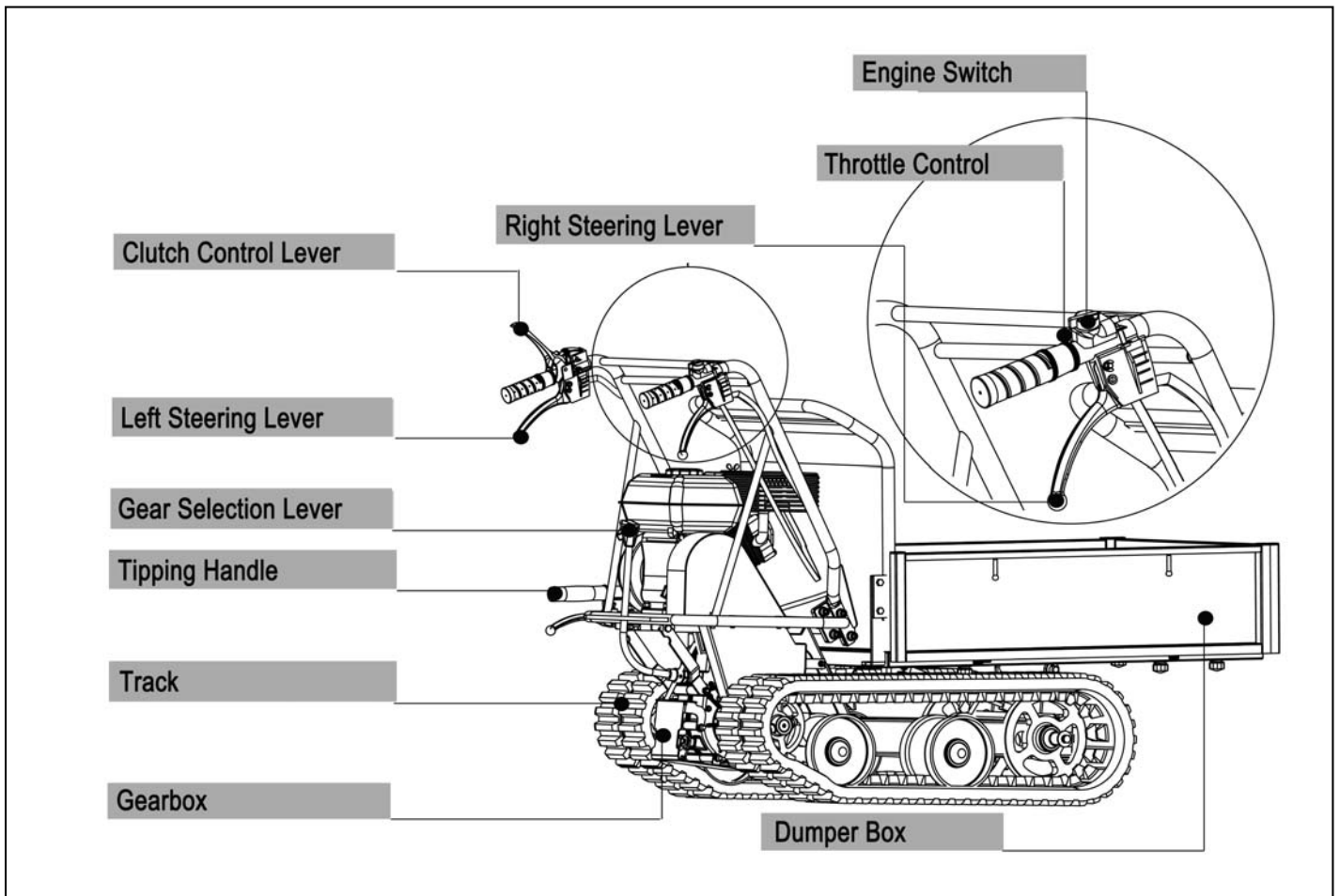

Engine switch

The engine switch enables and disables the ignition system.

The engine switch must be in the ON position for the engine to run.

Turning the engine switch to the OFF position stops the engine.

Clutch control lever

Squeeze the control lever, clutch engaged. Release the lever, clutch disengaged.

Throttle control

It controls engine speed. Put the throttle control on low speed (L) or high speed (H) or an intermediary position between L and H to increase or decrease the speed of engine.

Left steering lever

Operate the lever to turn left.

Right steering lever

Operate the lever to turn right.

Gear selection lever

It controls forward or reverse movements of the machine.

Tipping handle

It controls tipping of the dumper box. Pull the tipping handle up to raise the dumper box. Pull the tipping handle down to its original position, dumper box will be lowered and locked automatically. To check whether the dump box is locked securely, try to lift it without pulling up the tipping handle.

Mini Transporter Operation

Adding fuel

Fill the fuel tank as instructed in the separate Engine Manual packed with the machine.



Fill tank to no more than 12.5mm (1/2") below the bottom of the filler neck to provide space for expansion.

Starting engine

A more detailed description of the engine operation and all related precautions and procedures can be found in the Engine Manual packed separately with the mini transporter.

Follow the procedure below for cold starts:

1. Put the gear shift lever at the idle speed position .
2. Turn choke lever on the engine to full choke position.
3. Turn the engine switch on.
4. Pull the starting rope slowly several times to allow the gasoline to flow into the engine's carburetor. Then hold the start handle firmly and pull rope out a short distance until you feel some resistance. Then pull the rope smoothly and briskly, and allow rope to return gently. Do not let the rope snap back. If necessary, pull the rope several times until the engine starts.
5. Allow the engine to run for several seconds to warm up. Then, gradually move chock lever to "OPEN" position.



Please not to operate the direction change lever before the engine warming up after several seconds.

Restarting an engine that is already warm from previous running does not normally require use of the choke.

1. Set the throttle lever on the handlebar at half-way position.
2. Hold the start handle firmly and pull rope out a short distance until you feel some resistance. Then pull the rope smoothly and briskly, and allow rope to return gently. Do not let the rope snap back.

Operating

After engine warms up, slowly squeeze the clutch control lever, then engage the required gear. If the gear does not engage straight away, slowly release the clutch lever

and try again. In this way the mini transporter will start moving.

Pull throttle lever to accelerate engine speed.

The mini transporter has the steering levers on the handlebars and this makes steering very easy. To turn right or left, simply operate the corresponding right or left steering lever.

The sensitivity of the steering increases in proportion to the speed of the machine and that with the empty machine, a light pressure on the lever is all that is needed to turn. While when the machine is loaded, more pressure is required.

The mini transporter has a maximum capacity of 300kg. However, it is advisable to assess the load and adjust it according to the ground on which the machine will be used.

It is therefore advisable to cover such stretches using low gear and taking extra care. In such situations, the machine should be kept in low gear for the whole stretch.

Avoid sharp turns and frequent changes of direction while driving on the road, in particular on rough, hard terrains full of sharp, uneven points with a high degree of friction.

Even though the unit has rubber tracks, remember to be careful when working in adverse weather conditions (ice, heavy rain and snow) or on types of ground that could make the mini transporter unstable.

Please note that as this is a tracked vehicle, it is subject to a considerable pitching movement when passing over bumps, holes and steps.

When the clutch control lever is released, the machine will stop and brake automatically, throttle lever will be disabled.

If the machine is stopped on a steep slope, a wedge should be placed against one of the tracks.

Idle speed

Set throttle control lever to its "SLOW" position to reduce stress on the engine when working is not being performed. Lowering the engine speed to idle the engine will help extend the life of the engine, as well as conserve fuel and reduce the noise level of the machine.

Stopping engine

To stop the engine in an emergency, release the clutch control lever, then turn the engine switch to the OFF position. Under normal conditions, use the following procedure:

1. Move the throttle lever to the SLOW position.
2. Let engine idle for one or two minutes.
3. Turn the engine switch to the OFF position.
4. Turn the fuel valve lever to the OFF position.

 Do not move choke control to CHOKE to stop engine. Backfire or engine damage may occur.

MAINTENANCE

A proper maintenance and lubrication will help the machine in a perfect working condition.

Preventive maintenance

Turn off engine and disengage all command levers. Engine must be cool.

Inspect the general condition of the unit. Check for loose screws, misalignment or binding of moving parts, cracked or broken parts, and any other condition that may affect its safe operation.

Remove all debris and other materials that may have accumulated to the track and unit. Clean after each use. Then use a premium quality lightweight machine oil to lubricate all moving parts.

 Never use a "pressure washer" to clean your unit. Water can penetrate tight areas of the machine and its transmission case and cause damage to spindles, gears, bearings, or the engine. The use of pressure washers will result in shortened life and reduce Serviceability.

Adjusting clutch

As clutch wears out, the same lever could have a wider opening, being so uneasy to use. This means that it is necessary to adjust the cable, setting clutch lever on its original position acting on the adjustment device and on counter-nut.

Adjusting steering

If you have difficulty steering the unit, you will need to adjust the steering levers with the special adjusters. Slacken off the locknut and unscrew the adjusters to eliminate the play in the cable, which can occur after initial use or normal wear. Be very careful not to unscrew the adjusters too much because this can create another problem: the loss of traction. Remember to tighten the locknut when you have finished.

Lubrication

The gearbox is pre-lubricated and sealed at the factory.

Check oil level every 50 hours of working. Remove the plug and check, with machine horizontal, oil reaches the two notches. If necessary, add the oil.

Use portable tool lithium #0 grease such as Lubriplate 6300AA, Lubriplate GR-132, or Multifak, e.g. EP-O.

Oil must be replaced when hot by unscrewing filler cap and plug equipped with an oil dipstick. When oil is completely drained, replace filler cap and fill up with new oil.

Tightening tracks

With use, tracks tend to loosen. When operating with loose tracks, they tend to slip over the driving wheel causing it to jump its housing or to work in precarious situation, thus damaging wear to the housing.

To check track tightness, proceed as follows.

1. Set the machine on a flat surface with compact ground, better on an asphalt or stone pavement.
2. Lift the machine and set it on blocks or supports rated for the weight of the machine so that the tracks are approximately 100mm off the ground.
3. Measure the track midline vs. the horizontal line. The reading must not be more than 10-15mm.

If the distance is greater, proceed as follows.

1. Use the tipping handle to tip the dump box and set it on blocks or supports rated for the weight of the box.

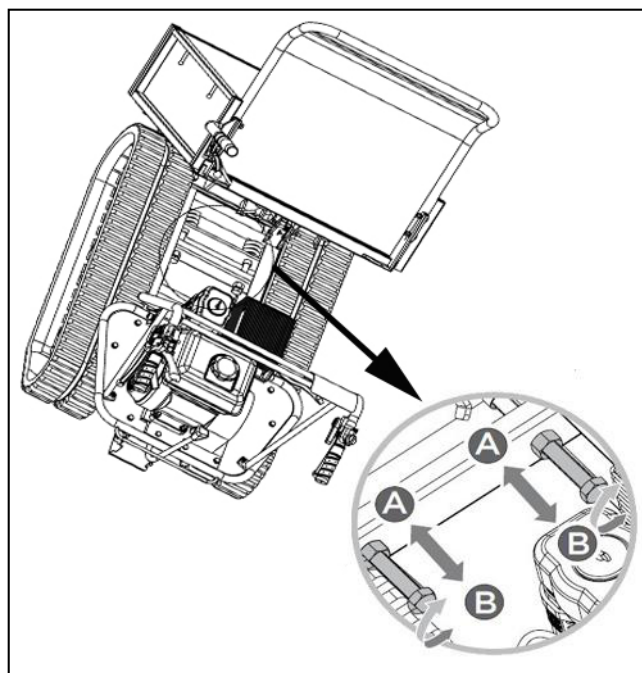

2. Loosen locknut A.

3. Tighten bolt B until the correct tightness is restored.
4. Secure bolt B by tightening locknut A thoroughly.
5. Return the dump box to its original position.



The adjustment of the track and the brakes are linked, therefore be very careful because if the track is over-tightened, the braking effect will be lost.



If the adjustment bolt has no more adjustment left, the tracks may have to be Replaced.

Replacing tracks

Check the condition of the tracks periodically. If any track is cracked or frayed, it should be replaced as soon as convenient.

1. Loosen the locknut A and bolt B shown in above figure to let the tracks loose enough.

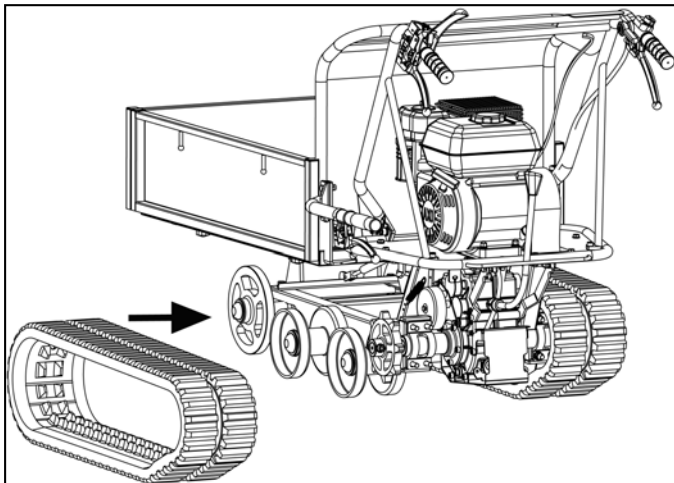

2. Slip the old tracks off and install the new tracks.
3. Adjust Bolt B to assure correct tightness.
4. Secure bolt B by tightening locknut A thoroughly.



When removing or installing the tracks, be careful not to get your fingers caught between the track and pulley.

Engine maintenance

Refer to the Engine Manual included in your unit for the information on engine maintenance. Your engine manual provides detailed information and a maintenance schedule for performing the tasks.

STORAGE

If the mini transporter will not be used for a period longer than 30 days, follow the steps below to prepare your unit for storage.

1. Drain the fuel tank completely. Stored fuel containing ethanol or MTBE can start to go stale in 30 days. Stale fuel has high gum content and can clog the carburetor and restrict fuel flow.
2. Start the engine and allow it to run until it stops. This ensures no fuel is left in the carburetor. Run the engine until it stops. This helps prevent gum deposits from forming inside the carburetor and possible engine damage.
3. While the engine is still warm, drain the oil from the engine. Refill with fresh oil of the grade recommended in the Engine Manual.
4. Use clean cloths to clean off the outside of the machine and to keep the air vents free of obstructions.



Do not use strong detergents or petroleum based cleaners when cleaning plastic parts. Chemicals can damage plastics.

5. Inspect for any loose or damaged parts. Repair or replace damaged parts and tighten loose screws, nuts or Bolts.
6. Store your unit on flat ground in a clean, dry building that has good ventilation.



Do not store the machine with fuel in a non-ventilated area where fuel fumes may reach flame, sparks, pilot lights or any ignition sources.

TROUBLE SHOOTING

Problem	Cause	Remedy
Engine fails to start.	<ol style="list-style-type: none"> 1. Spark plug wire disconnected. 2. Out of fuel or stale fuel. 3. Choke not in open position. 4. Blocked fuel line. 5. Fouled spark plug. 6. Engine flooding. 	<ol style="list-style-type: none"> 1. Attach spark plug wire securely to spark plug. 2. Fill with clean, fresh gasoline. 3. Throttle must be positioned at choke for a cold start. 4. Clean the fuel line. 5. Clean, adjust gap, or replace. 6. Wait a few minutes to restart, but do not prime.
Engine runs erratically.	<ol style="list-style-type: none"> 1. Spark plug wire loose. 2. Unit running on CHOKE. 3. Blocked fuel line or stale fuel. 4. Vent plugged. 5. Water or dirt in fuel system. 6. Dirty air cleaner. 7. Improper carburetor adjustment. 	<ol style="list-style-type: none"> 1. Connect and tighten spark plug wire. 2. Move choke lever to OFF. 3. Clean fuel line. Fill tank with clean, fresh gasoline. 4. Clear vent. 5. Drain fuel tank. Refill with fresh fuel. 6. Clean or replace air cleaner. 7. Refer to Engine Manual.
Engine overheats.	<ol style="list-style-type: none"> 1. Engine oil level low. 2. Dirty air cleaner. 3. Air flow restricted. 4. Carburetor not adjusted properly. 	<ol style="list-style-type: none"> 1. Fill crankcase with proper oil. 2. Clean air cleaner. 3. Remove housing and clean. 4. Refer to Engine Manual.
One of the two tracks is blocked.	Foreign bodies have worked their way between the track and the frame.	Remove the foreign body.
Machine does not move while engine is running.	<ol style="list-style-type: none"> 1. Gear is not properly selected. 2. Driving tracks not tight enough. 	<ol style="list-style-type: none"> 1. Ensure gear lever is not in-between two different gears. 2. Tighten driving tracks.

PARTS SCHEDULE

